

Artificial Sine Wave Generation Using SX Microcontroller



Application Note 11

Chris Fogelklou

June 1999

1.0 Introduction

Sine waves are used extensively in the telecommunications industry, and are traditionally difficult to implement in software without using code-consuming table lookups or complex math routines. One easy solution is to create an artificial sine wave, which utilizes the properties of gravity and creates a near-perfect sine wave. This signal is sufficient for applications such as DTMF (Dual-Tone Multi-Frequency) generation, FSK generation, PSK generation, and many other applications that require frequency generation.

In the past, telephony functions such as FSK (frequency-shift keying) generation and detection, DTMF (dual-tone, multi-frequency) dialing generation and detection, and Caller ID could not be implemented with an 8-bit embedded MCU because performance levels were not high enough to support them. As a result, either a custom MCU had to be designed or a 16- or 32-bit device be used. Now, the 8-bit Scenix Semiconductor SX Series MCUs, with performance reaching 100 MIPS (million instructions per second) and a deterministic interrupt architecture, overcome this roadblock by providing the ability to perform these functions in software.

Unlike other MCUs that add functions in the form of additional silicon, the SX Series uses its industry-leading performance to execute functions as software modules, or Virtual Peripheral™. These are loaded into a high-speed (10 ns access time) on-chip flash/EEPROM program memory and executed as required. In addition, a set of on-chip hardware peripherals is available to perform operations that cannot readily be done in software, such as comparators, timers, and oscillators.

2.0 How It Works

When a ball is thrown into the air, it has a constant downward acceleration until it has a velocity of zero. At this point it obtains a positive velocity towards the ground until it hits the ground. What were to happen if the ball were to continue through the ground, once again accelerating towards the ground? It would decelerate until its velocity reached zero and once again would gain velocity towards the ground. Passing the ground, it would begin decelerating and the cycle would continue...

This type of algorithm can be implemented in an interrupt service routine as shown in Figure 2-1.

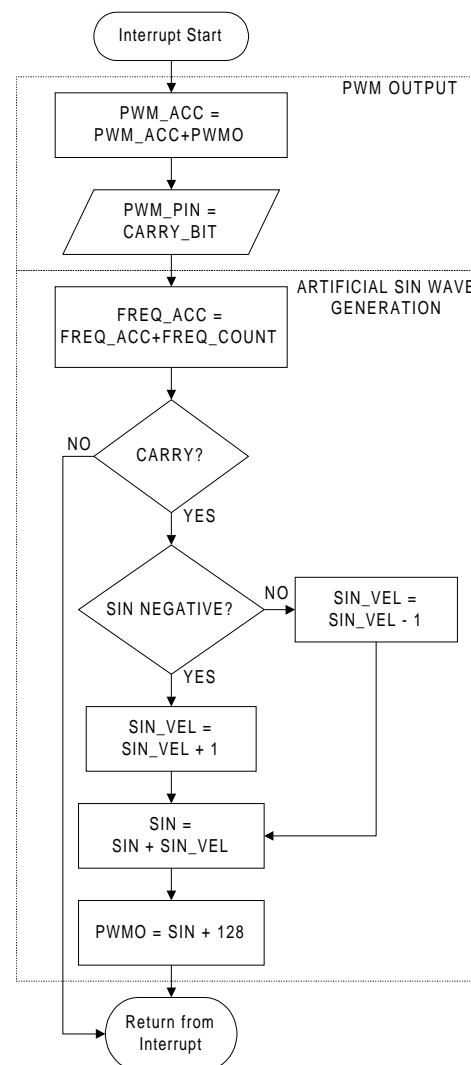

Figure 2-1. Interrupt Service Routine Flowchart

The first block of the interrupt service routine services the PWM, which serves as a D/A converter, outputting the current value of the sin wave to the external circuitry.

3.0 Timing

The initial step of the artificial sine wave generator is to determine if it is time to update the value of the sine wave. The 16-bit `FREQ_COUNT` register determines the rate at which the wave is updated. Each cycle of the wave is made up of 32 separate points, meaning that the 16-bit `FREQ_ACC` register must roll over 32 times to cycle through an entire period of the sine wave. If we combine these factors with the interrupt rate of 3.26us, we can calculate the value to load into the `FREQ_COUNT` register for any given frequency.

With a `FREQ_COUNT` value of 1, it will take 65536 interrupts for the 16-bit `FREQ_ACC` register to roll over.

One Period = 32 separate points.

Therefore, there will be 32 rollovers x 65536 interrupts for one period.

One Period = 2 097 152 interrupts

Since the ISR rate = 3.26us.

One period (s) is 2 097 152 x 3.26us = 6.836715520 s

Frequency = 0.14627Hz.

Resolution = 0.14627 Hz

Maximum output frequency = 9.6kHz.

Output frequency = `FREQ_COUNT` x 0.14627Hz

`FREQ_COUNT` = (desired frequency) x 6.83671552

The 16-bit value of `FREQ_COUNT` must be loaded into two separate 8-bit registers, `FREQ_COUNT_LOW` and `FREQ_COUNT_HIGH`.

4.0 Creating The Wave

The program just increments the velocity (accelerates) if the wave is negative, or decrements the velocity (decelerates) if the wave is positive. This new velocity is added to the current value of the sine wave. The final task is to load the new value of the sine wave into the PWM register, and to add #128 to the PWM output to center the wave at 2.5VDC.

5.0 Circuit Design

The simplest version of the circuit requires only two components for the PWM output, a resistor and a capacitor. Here is a block diagram of the circuit.

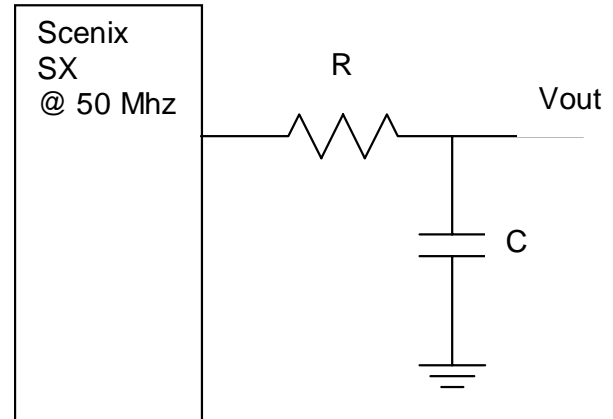

Figure 5-1. Circuit Diagram

Depending on the maximum frequency you wish to obtain, you should adjust the component values for R and C to choose the resolution of the PWM. Ideally, you should calculate the maximum sine frequency output you will use and choose the cutoff to be at this frequency. For instance, if your maximum output frequency will be 2.1kHz, calculate R and C:

First, choose a value for R.

R=1000 ohms

Now, calculate C:

$$C = 1/(2 * \pi * \text{Cutoff Frequency} * R)$$

Therefore:

$$C = 1/(2 * 3.14 * 2100\text{Hz} * 1000 \text{ ohms})$$

And

$$C = 0.076\mu\text{F}$$

