

The following is a copy of the provisional patent filed on behalf of Industrial Research Limited on 28 October 1994 - NZ Patent 264738

I developed this while building myself an anemometer, my interest is windsurfing and I was building a speech / telephone based weather station. Rather than build a multi-track grey code wind direction encoder unit I decided to see if I could create a single track system which would be easier to fabricate as I had few tools available (and less money). This encoding method was the result. Although I developed it for my own use I was employed by Industrial Research (IRL) at the time and there was an ambiguous clause in my contract relating to inventions that used skills or knowledge related to my work, which included electronics and automation, so I offered it to IRL and they decided to register a provisional patent. As far as I know nothing came of this and it has since lapsed.

It is only fairly recently that I discovered that "For many years, [Torsten Sillke](#) and other mathematicians believed that it was impossible to encode position on a single track such that consecutive positions differed at only a single sensor, except for the 2-sensor, 1-track quadrature encoder."

http://en.wikipedia.org/wiki/Single-track_Gray_code#Single-track_Gray_code

So this patent in fact was apparently the first proof that a single track encoder was possible.

I am aware that there are probably many solutions to this problem, but would be very interested to hear if anyone has used this design in a real world situation.

Bruce Spedding
winzurf@gmail.com

Key words: Grey code, encode, encoder, rotary, linear, binary, absolute, position

A POSITION ENCODER

We, INDUSTRIAL RESEARCH LIMITED, a New Zealand company, of Gracefield Road, Lower Hutt, New Zealand do hereby declare this invention to be described in the following statement:

The present invention comprises a versatile position encoder.

Rotary position encoders are used to indicate the angular position of a rotating mechanical member such as a rotating shaft for example. They comprise a disk which rotates with the rotating member, which has a series or pattern of lines marked on its surface or edge. As the disk rotates the lines or pattern on the disk switches a number of in-line optical detectors to produce at the outputs of the detectors at any instant a code, often referred to as a grey scale code, indicative of the angular position of the disk at that instant. The use of a grey code ensures that only one detector is switching at any instant, avoiding potential ambiguities in the transition zones. The disadvantage of such encoders is that the disks are not simple or cheap to fabricate, especially in one off situations.

The present invention provides an improved or at least alternative rotary or linear position encoder.

In broad terms in one aspect the invention comprises a position encoder for determining the angular or linear position of a rotating or linearly moving member, comprising an encoder element to rotate or linearly move with the member and which comprises a contrasting sector on at least one part of the periphery or length of the rotating or moving encoder element relative to other parts of the periphery or length of the encoder element, and a number of detectors which distinguish between the contrasting sector(s) and the remainder of the periphery or length of the rotating or moving encoder element, spaced from each other about the periphery or adjacent the length of the element.

Preferably the detectors are substantially equidistantly spaced from each other about the periphery or adjacent the length of the rotating or linearly moving encoder element.

Preferably the one or more contrasting sectors of the rotating or linearly moving encoder element are formed by one or more cutouts in the periphery of the rotating element.

In broad terms in another aspect the invention comprises a position encoder for determining the angular or linear position of a rotation or linearly moving member, comprising a number of detectors spaced from each other either radially about the axis of rotation of the rotating member and which rotate with the rotating member, or linearly along the axis of movement of the linearly moving member and which move with the linearly moving member, an encoder element encircling the radially spaced detectors or extending adjacent the linearly spaced detectors which comprises a contrasting sector on at least one part of the internal periphery or length of the encoder element relative to the other parts of the periphery or length of the encoder element, distinguishable between the contrasting sector(s) and the remainder of the periphery or length of the encoder element by the detectors.

Preferably the one or more contrasting sectors of the encoder element are formed by one or more cutouts in the periphery or length of the encoder element.

Preferably the detectors are substantially equidistantly spaced from each other about the axis of rotation of the rotating member or along the axis of movement of the linearly moving member.

The invention will be further described with reference to the accompanying drawings, by way of example. In the drawings:

Fig. 1 shows one form of conventional rotary position encoder,

Fig. 2 shows eight positions of a preferred form four detector, single cutout rotary position encoder of the invention,

Fig. 3 shows a preferred form five detector, single cutout rotary position encoder of the invention showing the cutout angle and two positions thereof,

Fig. 4 shows a preferred form six detector, two rotary position encoder of the invention showing the angles and four positions thereof,

Fig. 5 shows a preferred form nine detector, two rotary position encoder of the invention showing the angles and four positions thereof,

Fig. 6 shows in Fig. 6a a preferred form twelve detector, three cutout rotary position encoder of the invention showing in Fig. 6a the cutout angles and in Fig. 6b six positions thereof,

Fig. 7 shows a thirty six detector, five cutout position encoder of the invention showing the cutout thereof,

Fig. 8 shows an eighteen detector, four cutout position encoder of the invention showing the cutout thereof, and

Fig. 9a shows a preferred form twelve detector, nine cutout linear position encoder of the invention, Fig. 9b shows the detector array thereof in more detail, Fig. 9c shows one segment of the encoder element thereof, and Fig. 9d shows six positions thereof.

Referring to Fig. 1, a conventional grey scale rotary position encoder comprises a disk which is fixed to the rotating member such as a rotating shaft, and which has thereon a series of concentric tracks as shown. The encoder also comprises a number of in-line optical detectors each arranged to align with one of the concentric tracks. The sensor outputs provide a

binary code indicating the angular position of the disk, and thus of the member to which the disk is attached which in the case of the three track encoder having three detectors A, B and C shown in Fig. 1 is a three hit binary code. The table in Fig. 1 shows the three bit binary sequence for each of the eight angular positions of the encoder disk that can be detected. In Fig. 1 the disk is shown in the N position.

Fig. 2 shows one preferred form of rotary position encoder of the invention, which in this case is a four detector single cutout encoder. The eight angular positions of the encoder element which at the outputs of the detectors A, B, C & D each provide a unique 4 bit binary code indicating the angular position of the rotating encoder element are shown and the

binary codes are also shown in the table of Fig. 2. The encoder disk comprises a cutout around 135° of the periphery of the disk which forms a contrasting sector about that part of the periphery of the disk, relative to the remainder of the periphery of the disk.

When the cutout of the disk overlaps one of the optical detectors A, B, C or D, the output of the detector is one binary state e.g. 0, whereas when the other part of the periphery of the disk overlaps the sensor the output of the sensor is the other binary state e.g. 1. The encoder of Fig. 2 provides a resolution of 45 degrees.

Fig. 3 shows a rotary encoder of the invention with five detectors and a single cutout of 108°, providing a resolution of 36°. The ten unique five bit binary words each corresponding to a different angular position of the rotating element are shown in the table in Fig. 3 along with two different positions of the encoder element by way of example.

Fig. 4 shows a rotary encoder of the invention with six detectors and two cutouts of 75° and 135°, spaced from each other by two 75° intervals, providing a resolution of 15°. The twenty four, six bit binary words each corresponding to a different angular position of the rotating element are shown in the table in Fig. 4, along with four different positions of the encoder element by way of example.

Fig. 5 shows a rotary encoder of the invention with nine detectors and two cutouts of 90° and 50°, spaced by intervals of 170° and 60°, providing a resolution of 10°. The thirty six, nine bit binary words, each corresponding to a different angular position of the rotating element are shown in the table in Fig. 5, along with four different positions of the encoder element by way of example.

Fig. 6 shows a rotary encoder of the invention with twelve detectors and three cutouts of 95°, 65° and 35°, spaced from each other by intervals of 35° (clockwise following the 90° cutout), 35° (clockwise following the 65° cutout), and 95° (clockwise following the 35° cutout), providing a resolution of 5°. The seventy two unique nine bit binary words each corresponding to a different angular position of the rotating element are shown in the table in Fig. 6a, along with six different positions of the encoder element by way of example in Fig. 6b.

Fig. 7 shows a rotary encoder of the invention with thirty six detectors and five cutouts of 51°, 41°, 31°, 21°, and 11° spaced from each other by intervals of 11° (following the 51° cutout), 11° (following the 41° cutout), 11° (following the 31° cutout), 11° (following the 21° cutout), and 161° (following the 11° cutout), providing a resolution of 1°.

Fig. 8 shows a rotary encoder of the invention with eighteen detectors and four cutouts of 82.5°, 62.5°, 42.5° and 22.5°, spaced from each other by intervals of 22.5° (following the 82.5° cutout), 22.5° (following the 62.5° cutout), 22.5° (following the 42.5° cutout), and 82.5° (following the 22.5° cutout), providing a resolution of 2.5°.

Generally in rotary position encoders of the invention, increasing the number of detectors and contrasting sectors or cutouts increases the resolution according to the formula:

$$\text{Resolution } a^\circ = 360 / (n \cdot 2 \cdot c)$$

where n = number of detectors
and c = number of Cutouts

c has a maximum value of
 1 for $n < 6$
 2 for $6 \leq n \leq 10$
 3 for $11 \leq n \leq 16$
 4 for $17 \leq n \leq 23$
 5 for $24 \leq n < 32$ etc.

Hence, increasing to 5 detectors gives a resolution of 36° while at 6 detectors the number of "cutouts" may be increased to 2 and the resolution improves to 15° . The formula holds for 7 (12.9°), 8 (11.25°), 9 (10°) and 10 detectors (9°). At 11 detectors a third cutout may be included and the resolution becomes 5.5° while 12 will give 5° . The next significant change in resolution is at 17 detectors giving 2.6° with 4 cutouts. To get to better than 1° resolution requires 32 detectors and 5 Cutouts giving 0.94° . Obviously such an angular resolution may be less desirable than exactly 1° , so the table below lists some sensor/cutout combinations which yield useful exact increments.

Number of Sensors	Number of Cutouts	Resolution (degrees)
4	1	45.0
5	1	36.0
6	2	15.0
9	2	10.0
12	3	5.0
15	3	4.0
18	4	2.5
20	4	2.25
30	3	2.0
24	5	1.5
36	5	1.0

To design a coding pattern choose n and c values to give the desired resolution a° . The first cutout will be $(2c+1) \cdot a^\circ$ wide, the second $(4c+1) \cdot a^\circ$, the third $(6c+1) \cdot a^\circ$ and so on. The cutouts are spaced $(s \cdot c+1) \cdot a^\circ$ apart, where s is a positive integer .

To explain the formula, the n detectors are equi-spaced around the disk giving a basic angle (sector) resolution of $360/n^\circ$. The cutouts are arranged in such a way that all edges pass a detector somewhere on the circumference once each time the disk rotates through this angle, with no two edges passing at the same time and all edges being equi-spaced.. Since each cutout has two edges this means there are $2 \cdot c$ (edges) passing per sector, and there are n sectors (detectors) per full rotation, giving $n \cdot 2 \cdot c$ transitions in total.

Alternative to the detectors being spaced about the periphery of the rotating encoder element and contrasting sectors being provided on the periphery of the encoder element, the positions of the detectors and rotating encoder element may be reversed. The detectors may be mounted to rotate with the rotating member and the rotating detectors may be

encircled by an encoder element which is fixed, having contrasting sectors formed about the internal edge of the fixed circular encoder element which may be sensed by the detectors.

Instead of being formed by a cutout, the contrasting sector(s) of the periphery of the disk can be made to be a contrasting colour e.g. white relative to the remainder of the periphery of the disk which may be coloured black for example.

Alternatively, the contrasting sector could be formed by applying reflecting tape to the periphery or edge of the disk. Any variations which allow for detection between the different sectors of the encoder disk are possible.

It is not essential that the detectors used be optical detectors as for example the rotating disk or member may be formed so that the contrasting sectors of the disk periphery (equivalent to the cutout) are magnetically different and magnetic detectors may be used for example and other forms, conductive, ultrasonic etc.

Figs 9a to 9d show one preferred form of linear position encoder of the invention, which in this case is a twelve detector, three cutout encoder. Either of the detectors of encoder element comprising the cutouts forming the contrasting sectors may move one relative to the other.

Fig. 9b shows the detector array in more detail - in the form shown the detectors are equidistantly spaced by 30 length units from one another, while Fig. 9c shows one segment of the encoder element showing the three cutouts of 35 unit lengths and 95 unit lengths (left to right) spaced from each other by 35 unit lengths, 65 unit lengths, and 95 unit lengths (left to right) as shown. The encoder segment may be duplicated as shown in Fig. 9a to allow for longer travel. For example the total encoder element length may be two times the segment length.

The maximum working range is the segment length.

Referring to the drawings, using location 1 as a reference point on the detector array, the range of travel could be between 2 and 4, in which case the segment from 6 to 9 is not required. Travel between 3 and 5 requires the section of the encoder from 3 to 7, between 4 and 6 requires 4 to 8, that is the segment from 2 to 4 may be omitted. The linear resolution in the version shown as 1s 5 length units. Linear encoders similar to rotary encoders, with a greater or lesser number of detectors and cutouts may be formed based on the form shown in Fig. 9 but following the example of the rotary encoder variations previously described. The first six unique 12 bit binary words each corresponding to a different linear position of the encoder are shown in the table in Fig. 9d along with the corresponding first six different positions of the encoder by way of example.

In rotary and linear position encoders of the invention the output from the detector array may be decoded to determine the angle or linear position by using a pattern matching (lookup table) technique. The following describes an alternative method.

The output from the detector array is a binary code which is unique for each angular step, and of which 1 and only 1 digit changes for each step in angular position. The same pattern of digits (1s and 0s) repeats periodically during the rotation, however the pattern is rotated each time by 1 digit, that is the pattern is shifted to the left or right and any digit which "overflows" is inserted at the right or left end of the sequence respectively. The repetition rate is determined by the spacing of the detectors, for example part of the output for a 5 degree encoder comprising 12 detectors and 3 cutouts is shown below.

Examination of the codes shows that the pattern for angle 0 repeats at angle 30 but rotated to the left one digit (ie A->B, B->C and so on to L->A), and this process is repeated at angle 60, where the pattern at angle 30 occurs but rotated 1 digit to the left.

```
Angle L K J I H G F E D C B A
0 0 0 1 0 0 1 0 0 0 1 1 1
5 0 1 1 0 0 1 0 0 0 1 1 1
10 0 1 0 0 0 1 0 0 0 1 1 1
15 0 1 0 0 1 1 0 0 0 1 1 1
20 0 1 0 0 1 0 0 0 0 1 1 1
25 0 1 0 0 1 0 0 0 1 1 1 1
30 0 1 0 0 1 0 0 0 1 1 1 0
35 1 1 0 0 1 0 0 0 1 1 1 0
40 1 0 0 0 1 0 0 0 1 1 1 0
45 1 0 0 1 1 0 0 0 1 1 1 0
50 1 0 0 1 0 0 0 0 1 1 1 0
55 1 0 0 1 0 0 0 1 1 1 1 0
60 1 0 0 1 0 0 0 1 1 1 0 0
```

This repetition can be used to decode the position code.

In the example above, by rotating the code to the right (L->K,K->J etc. A->L) until at positions A, B and C are all 1, and position L is 0.

The number of rotations required (0,1,2 etc.) multiplied by the detector angle (30 degrees) is then added to the angle (0,5,10,15,20,25) whose pattern now matches the shifted result. In rotary and linear position encoders of the invention, preferably the spacing between detectors is equal but unequal spacing is possible, or the cutouts may vary in size from those calculated using the methods described provided:

(a) the distance between any two detectors (not just adjacent detectors) is never equal to the distance between any two cutout edges (not just adjacent or consecutive edges), as this would violate the unambiguous (Grey Code) code generation.

(b) the spacing of detectors and size of cutouts does not lead to a loss of uniqueness (ie repetition) in the code generated over the desired range. In particular this means that the difference in size of all cutouts must be greater than the minimum spacing between any two adjacent detectors. Other conditions may also apply. The effect of irregularly spaced detectors would be to vary the angular step size resolution.

The forgoing describes the invention including a preferred form thereof. Alterations and modifications as will be obvious to those skilled in the art are intended to be incorporated within the scope hereof.

WEST-WALKER MCCABE
per:
ATTORNEYS FOR THE APPLICANT

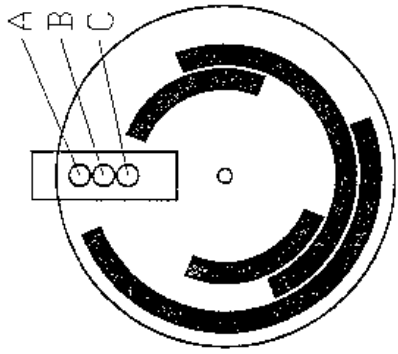

A	B	C
N	NE	E
SE	S	SW
W	NW	
000	001	011
010	110	111
101	100	

Fig. 1

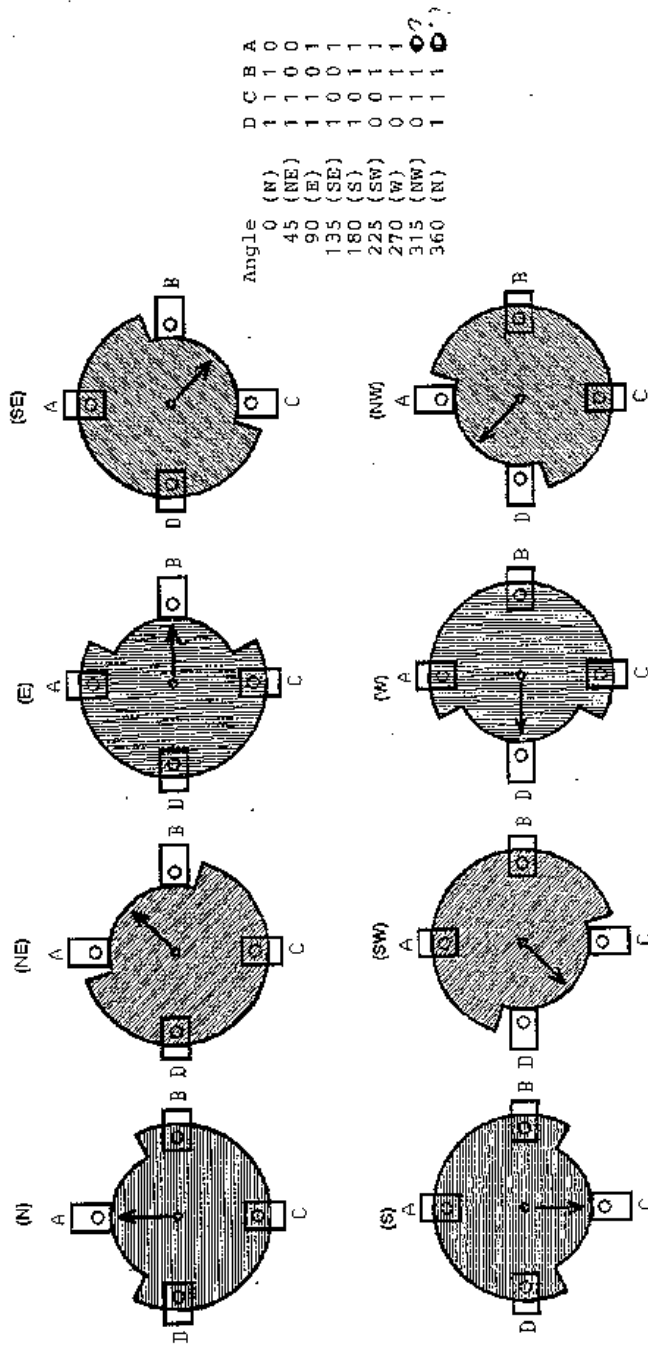
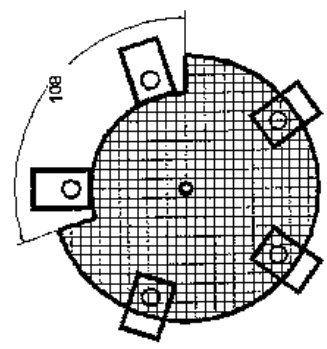
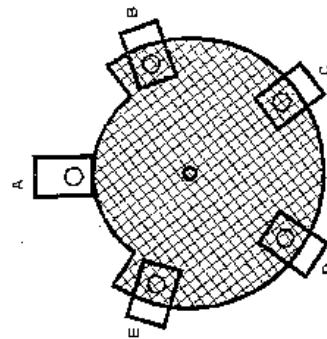
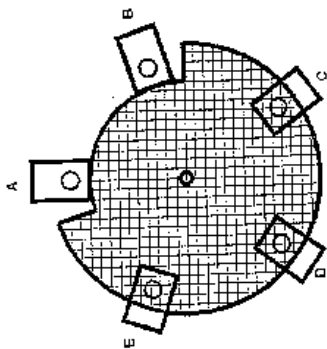
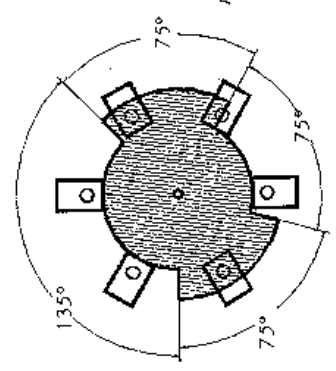
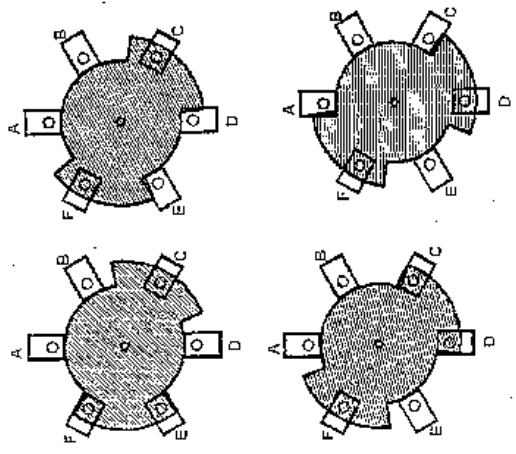

Fig. 2



Angle	E	D	C	B	A
0	1	1	1	1	0
36	1	1	1	0	0
72	1	1	0	1	0
108	1	1	0	1	1
144	1	1	0	1	1
180	1	0	0	1	1
216	1	0	1	1	1
252	0	0	1	1	1
288	0	1	1	1	1
324	0	1	1	1	0
360	1	1	1	1	0

Fig. 3



Angle	F	E	D	C	B	A
0	1	1	1	1	1	1
15	1	1	1	1	1	0
30	1	1	1	1	1	0
45	1	1	1	1	1	0
60	1	1	1	1	1	0
75	1	1	1	1	1	0
90	0	1	1	1	1	0
105	0	1	1	1	1	0
120	0	1	1	1	1	0
135	0	1	1	1	1	0
150	0	1	1	1	1	0
165	0	1	1	1	1	0
180	0	1	1	1	1	0
195	0	1	1	1	1	0
210	0	1	1	1	1	0
225	0	1	1	1	1	0
240	0	1	1	1	1	0
255	0	1	1	1	1	0
270	0	1	1	1	1	0
285	0	1	1	1	1	0
300	0	1	1	1	1	0
315	0	1	1	1	1	0
330	0	1	1	1	1	0
345	0	1	1	1	1	0
360	1	1	1	1	1	1

Fig. 4

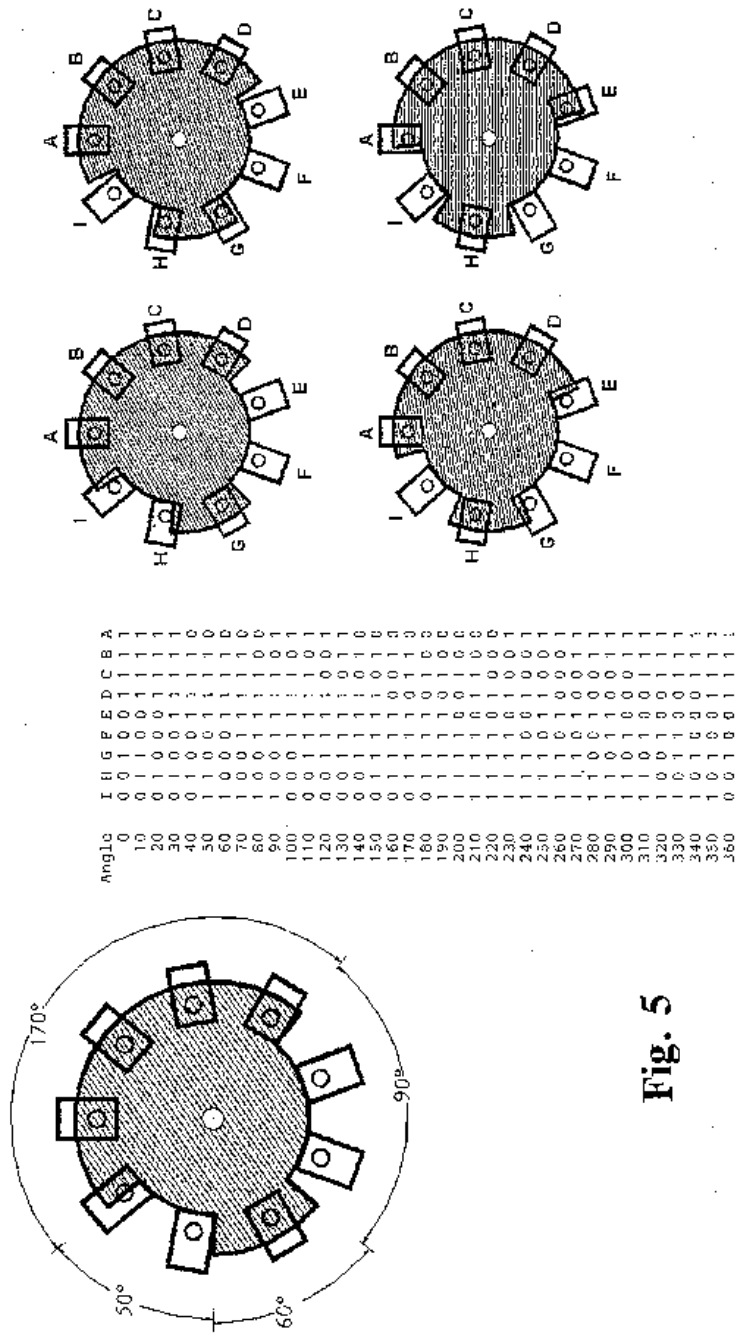

Fig. 5

Angle	Z	X	J	I	H	G	F	E	D	C	B	A
0	0	0	1	0	0	1	0	0	0	1	1	1
5	0	1	1	0	0	1	0	0	0	1	1	1
10	0	1	0	0	0	1	0	0	0	1	1	1
15	0	1	0	0	1	1	0	0	0	1	1	1
20	0	1	0	0	1	0	0	0	0	1	1	1
25	0	1	0	0	1	0	0	0	1	1	1	1
30	0	1	0	0	1	0	0	0	1	1	1	0
35	1	1	0	0	1	0	0	0	1	1	1	0
40	1	0	0	0	1	0	0	0	1	1	1	0
45	1	0	0	1	1	0	0	0	1	1	1	0
50	1	0	0	1	0	0	0	0	1	1	1	0
55	1	0	0	1	0	0	0	1	1	1	1	0
60	1	0	0	1	0	0	0	1	1	1	0	0
65	1	0	0	1	0	0	0	1	1	1	0	1
70	0	0	0	1	0	0	0	1	1	1	0	1
75	0	0	1	1	0	0	0	1	1	1	0	1
80	0	0	1	0	0	0	0	1	1	1	0	1
85	0	0	1	0	0	0	1	1	1	1	0	1
90	0	0	1	0	0	0	1	1	1	0	0	1
95	0	0	1	0	0	0	1	1	1	0	1	1
100	0	0	1	0	0	0	1	1	1	0	1	0
105	0	1	1	0	0	0	1	1	1	0	1	0
110	0	1	0	0	0	0	1	1	1	0	1	0
115	0	1	0	0	0	1	1	1	1	0	1	0
120	0	1	0	0	0	1	1	1	0	0	1	0
125	0	1	0	0	0	1	1	1	0	1	1	0
130	0	1	0	0	0	1	1	1	0	1	0	0
135	1	1	0	0	0	1	1	1	0	1	0	0
140	1	0	0	0	0	1	1	1	0	1	0	0
145	1	0	0	0	1	1	1	1	0	1	0	0
150	1	0	0	0	1	1	1	0	0	1	0	0
155	1	0	0	0	1	1	1	0	1	0	0	0
160	1	0	0	0	1	1	1	0	1	0	0	0
165	1	0	0	0	1	1	1	0	1	0	0	1
170	0	0	0	0	1	1	1	0	1	0	0	1
175	0	0	0	1	1	1	1	0	1	0	0	1
180	0	0	0	1	1	1	1	0	1	0	0	1
185	0	0	0	1	1	1	0	1	1	0	0	1
190	0	0	0	1	1	1	0	1	1	0	0	1
195	0	0	0	1	1	1	0	1	1	0	0	1
200	0	0	0	1	1	1	0	1	1	0	0	1
205	0	0	1	1	1	1	0	1	0	0	1	0
210	0	0	1	1	1	1	0	1	0	0	1	0
215	0	0	1	1	1	0	1	1	0	0	1	0
220	0	0	1	1	1	0	1	1	0	0	1	0
225	0	0	1	1	1	0	1	0	0	1	1	0
230	0	0	1	1	1	0	1	0	0	1	0	0
235	0	1	1	1	1	0	1	0	0	1	0	0
240	0	1	1	1	0	0	1	0	0	1	0	0
245	0	1	1	1	0	1	1	0	0	1	0	0
250	0	1	1	1	0	1	0	0	0	1	0	0
255	0	1	1	1	0	1	0	0	1	1	0	0
260	0	1	1	1	0	1	0	0	1	0	0	0
265	1	1	1	1	0	1	0	0	1	0	0	0
270	1	1	1	0	0	1	0	0	1	0	0	0
275	1	1	1	0	0	1	0	0	1	0	0	0
280	1	1	1	0	0	1	0	0	1	0	0	0
285	1	1	1	0	1	0	0	1	1	0	0	0
290	1	1	1	0	1	0	0	1	1	0	0	0
295	1	1	1	0	1	0	0	1	1	0	0	0
300	1	1	1	0	1	0	0	1	1	0	0	1
305	1	1	0	1	1	0	0	1	1	0	0	1
310	1	1	0	1	0	0	1	1	0	0	0	1
315	1	1	0	1	0	0	1	1	0	0	0	1
320	1	1	0	1	0	0	1	1	0	0	0	1
325	1	1	0	1	0	0	1	1	0	0	0	1
330	1	0	0	1	0	0	1	1	0	0	0	1
335	1	0	1	1	0	0	1	1	0	0	0	1
340	1	0	1	0	0	0	1	1	0	0	0	1
345	1	0	1	0	0	1	1	0	0	0	0	1
350	1	0	1	0	0	1	0	0	0	0	1	1
355	1	0	1	0	0	1	0	0	0	1	1	1
360	0	0	1	0	0	1	0	0	0	1	1	1

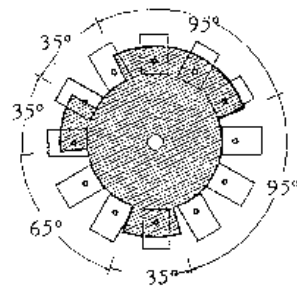

Fig. 6a

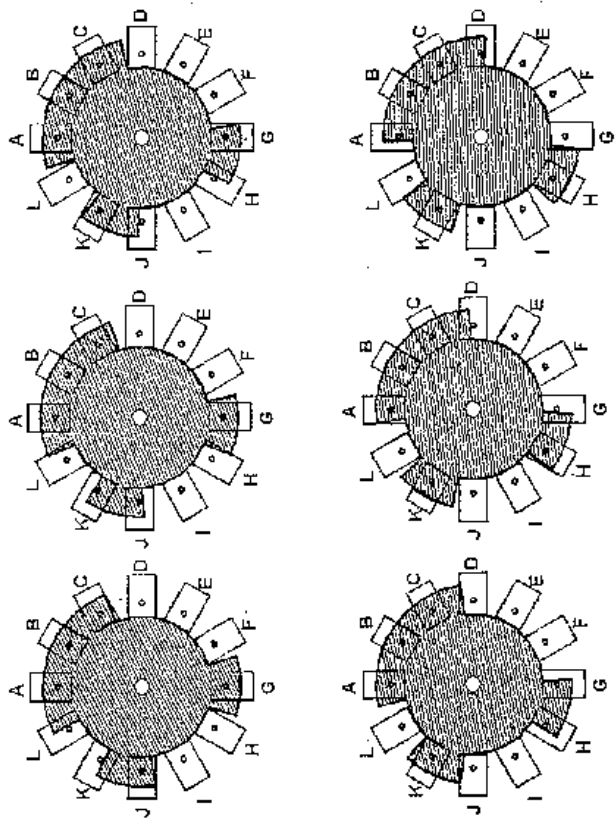

Fig. 6b

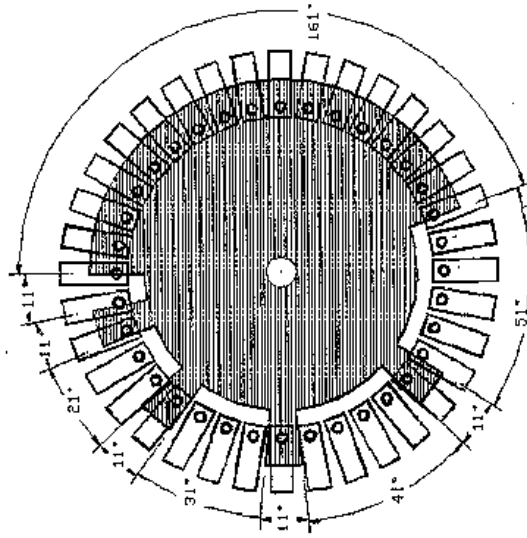

Fig. 7

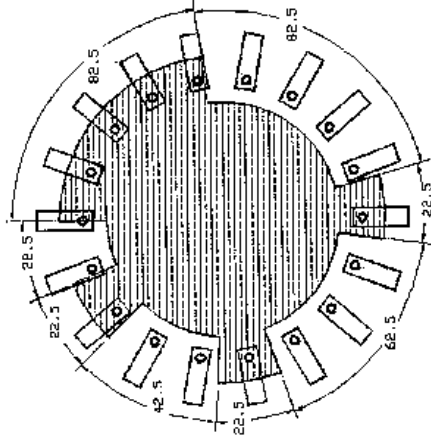

Fig. 8

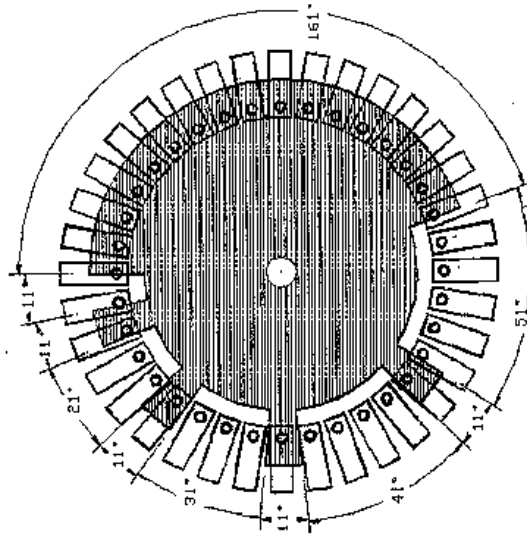

Fig. 7

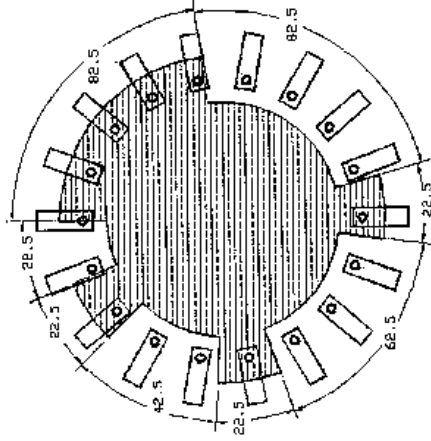

Fig. 8

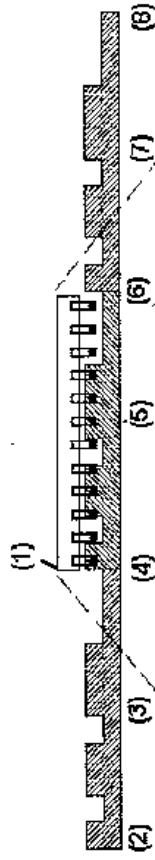

Fig. 9a

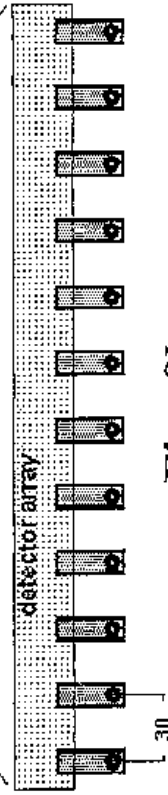

Fig. 9b

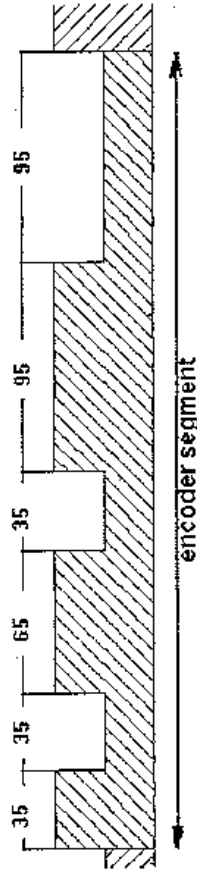
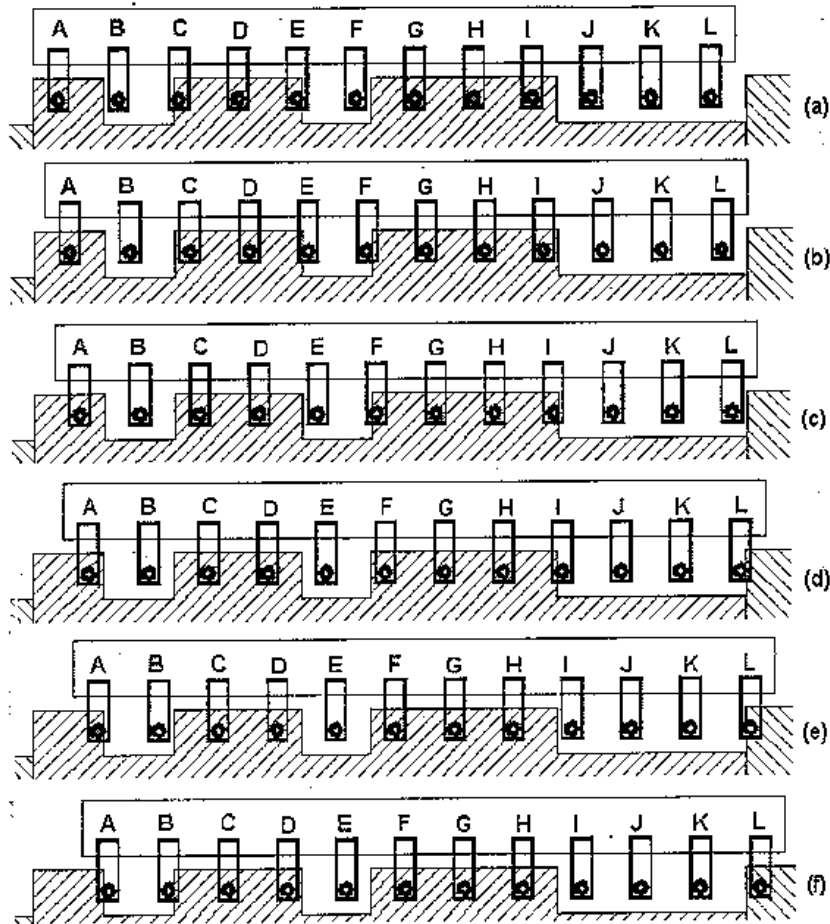

Fig. 9c



Travel	L	K	J	I	H	G	F	E	D	C	B	A
0	0	0	0	1	1	1	0	1	1	1	0	1
5	0	0	0	1	1	1	0	0	1	1	0	1
10	0	0	0	1	1	1	1	0	1	1	0	1
15	0	0	0	0	1	1	1	0	1	1	0	1
20	1	0	0	0	1	1	1	0	1	1	0	1
25	1	0	0	0	1	1	1	0	1	1	0	0
etc.												

Fig. 9d

